

# C600S Power Package

High-pressure Natural Gas

The Signature Series Microturbine provides 600kW of reliable electrical power in one small, ultra-low emission, and highly efficient package.



C600S Power Package

## Electrical Performance<sup>(1)</sup>

Electrical Power Output	600kW
Voltage	400/480 VAC
Electrical Service	3-Phase, 4 Wire Wye
Frequency	50/60 Hz
Electrical Efficiency LHV	33%

## Fuel/Engine Characteristics<sup>(1)</sup>

Natural Gas HHV	30.7–47.5 MJ/m <sup>3</sup> (825–1,275 BTU/scf)
Inlet Pressure	517–551 kPa gauge (75–80 psig)
Fuel Flow HHV	7,200 MJ/hr (6,840,000 BTU/hr)
Net Heat Rate LHV	10.9 MJ/kWh (10,300 BTU/kWh)

## Exhaust Characteristics<sup>(1)</sup>

NOx Emissions @ 15% O <sub>2</sub>	< 9 ppmvd (18 mg/m <sup>3</sup> )
Exhaust Mass Flow	4.0 kg/s (8.8 lbm/s)
Exhaust Gas Temperature	280°C (535°F)

## Benefits

- Ultra-low emissions
- One moving part – minimal maintenance and downtime
- Patented air bearings – no lubricating oil or coolant
- Integrated utility synchronization – no external switchgear
- Compact modular design allows for easy, low-cost installation
- High electrical efficiency over a very wide operating range
- High availability – part load redundancy
- Remote monitoring and diagnostic capabilities
- Proven technology with tens of millions of operating hours
- Various Factory Protection Plans available

**Smarter Energy  
for a Cleaner Future**

## Dimensions & Weight<sup>(2)</sup>

Width x Depth x Height	3.0 x 5.8 x 3.0 m (117 x 230 x 119 in)
Weight - Grid Connect Model	11,250 kg (24,800 lbs)
Weight - Dual Mode Model	13,350 kg (29,400 lbs)

## Minimum Clearance Requirements<sup>(3)</sup>

Horizontal Clearance	
Left	1.5 m (60 in)
Right	0.0 m (0 in)
Front	1.7 m (65 in)
Rear	2.2 m (85 in)

## Certifications

- UL 2200 Listed
- CE Certified
- Certified to the following grid interconnections standards: UL 1741-SA, VDE, BDEW, CEI 0-16, AS4777
- Compliant to California Rule 21

## C200 Engine Components

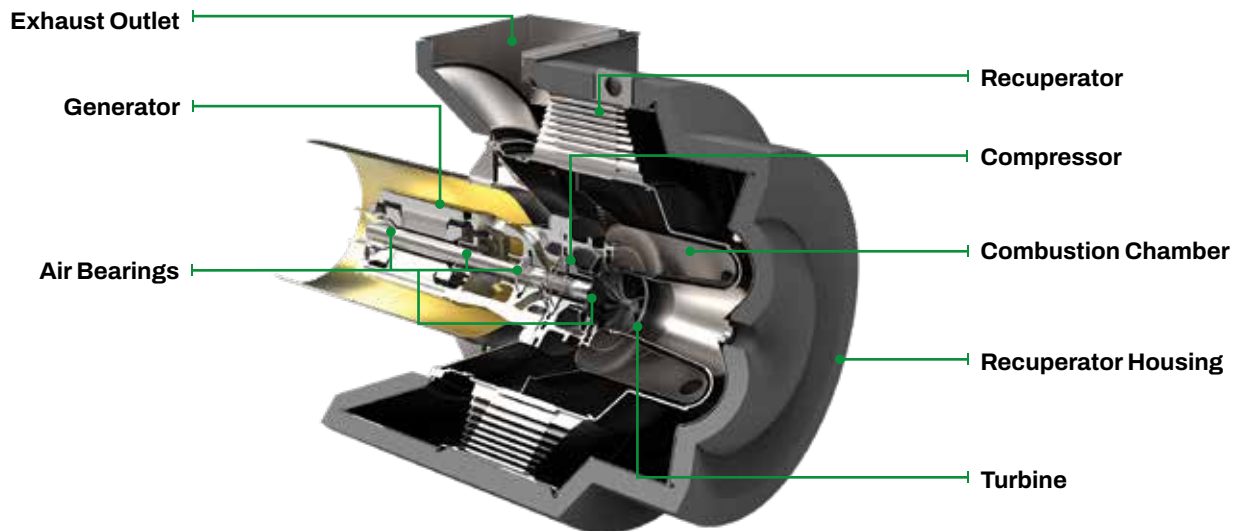

(1) Nominal full power performance at ISO conditions: 15°C (59°F), 14.696 psia, 60% RH

(2) Approximate dimensions and weights

(3) Clearance requirements may increase due to local code considerations

Specifications are not warranted and are subject to change without notice.